

Windham Weaponry

OPERATING & SAFETY MANUAL

PUMP-ACTION SHOTGUNS



WARNING: This product can expose you to chemicals including lead, which are known to the State of California to cause cancer and birth defects or other reproductive harm. For more information go to www.p65Warnings.ca.gov.

**READ THE INSTRUCTIONS AND WARNINGS IN
THIS MANUAL BEFORE USING THIS SHOTGUN!**

INDEX

1. SAFETY RULES
2. NOMENCLATURE
3. INITIAL ASSEMBLY AND INSPECTING
4. SAFETY BUTTON
5. LOADING AND USAGE
6. UNLOADING
7. DISASSEMBLY
8. REASSEMBLY
9. LOP SPACERS
10. ADJUSTABLE STOCK
11. USE OF CHOKE TUBES
12. PARTS LIST
13. EXPLODED VIEW
14. CLEANING AND MAINTENANCE

BECAUSE OF THE TRAPPED MOISTURE THAT MAY CAUSE RUSTING IT IS NOT ADVISABLE TO STORE YOUR SHOTGUN IN A CARRY CASE.

1-SAFETY RULES

WARNING: THE FAILURE TO FOLLOW THESE SHOTGUN SAFETY REQUIREMENTS WILL CAUSE SERIOUS PERSONAL INJURY OR DEATH TO YOU OR OTHERS.

- ALWAYS TREAT A FIREARM AS IF IT WERE LOADED. NEVER ASSUME THAT IT IS UNLOADED.
- NEVER POINT THE FIREARM AT SOMETHING THAT IS NOT SAFE TO SHOOT.
- ALWAYS STORE FIREARMS TO PREVENT CHILDREN FROM HAVING ACCESS TO THEM. IT IS YOUR RESPONSIBILITY TO INSURE THAT UNAUTHORIZED PERSONS DO NOT GAIN ACCESS TO YOUR FIREARM. TO REDUCE THE RISK OF ACCIDENTS INVOLVING CHILDREN, UNLOAD YOUR FIREARM, LOCK IT AND STORE THE AMMUNITION IN A SEPARATE LOCKED LOCATION.
- ALWAYS WEAR ADEQUATE AND PROPER EAR PROTECTION.
- ALWAYS WEAR SAFETY PROTECTIVE GLASSES SPECIFIED FOR FIREARM USE.
- ALWAYS BE ALERT AND ALWAYS FOLLOW THE SAFETY INSTRUCTIONS OF THE RANGE OFFICER. NEVER SHOOT IF YOU ARE TIRED, COLD OR IMPAIRED IN ANY WAY.
- ALWAYS BE AWARE OF YOUR SURROUNDINGS, AND BE ALERT THAT PEOPLE CAN WALK INTO YOUR LINE OF FIRE.
- THE SHOOTER (AND ALL OTHERS IN THE SHOOTING AREA) MUST ALWAYS BE IN A POSITION THAT IS OUT OF THE LINE OF FIRE.
- NEVER SHOOT AT HARD SURFACES, WATER OR RANDOMLY INTO THE SKY. ALWAYS SELECT A PLACE TO SHOOT THAT HAS A SAFE BACKSTOP AND IS FREE FROM OBSTRUCTIONS AND WATER SURFACES WHICH CAUSE RICOCHETS.
- NEVER CLIMB A TREE, FENCE OR OBSTRUCTION WITH A LOADED FIREARM. OPEN AND EMPTY THE CHAMBER OF YOUR FIREARM AND ENGAGE THE MANUAL SAFETY BEFORE CLIMBING OR DESCENDING A TREE OR BEFORE CLIMBING A FENCE OR JUMPING OVER A DITCH OR OBSTRUCTION.
- NEVER TRANSPORT A LOADED FIREARM.
- NEVER USE ALCOHOL OR DRUGS BEFORE OR WHILE SHOOTING OR HANDLING ANY FIREARM.

NOTICE

Discharging firearms in poorly ventilated areas, cleaning firearms, or handling ammunition may result in exposure to lead and other substances known to the State of California to cause birth defects, reproductive harm, and other serious physical injury. Have adequate ventilation at all times. Wash hands thoroughly after exposure.

2-NOMENCLATURE

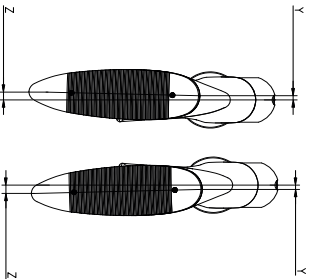
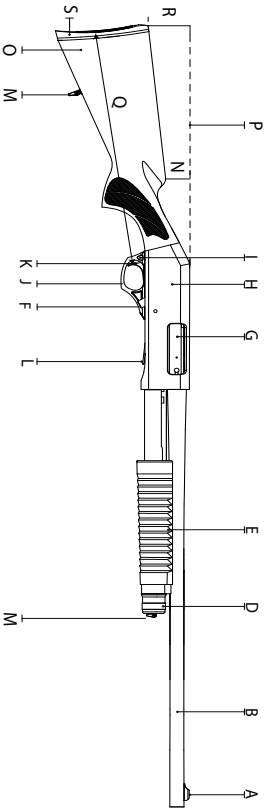

- A** Front Sight
- B** Barrel
- D** Forend Retaining Nut
- E** Forend
- F** Action Release Lever
- G** Bolt (Complete)
- H** Receiver
- I** Safety
- J** Trigger Group Housing
- K** Trigger
- L** Carrier
- M** Stock Swivel (Complete)
- N** Drop at Comb
- O** Stock
- P** Line of Sight
- Q** Length of Pull
- R** Drop at Heel
- S** Butt Plate / Recoil Pad
- Y** Top Advance Angle
- Z** Bottom Advance Angle

3-INITIAL ASSEMBLY AND INSPECTING

- Below is a picture of a shotgun with the barrel assembled to the receiver (Figure 1)*.



* Depends on the country or region.

4-SAFETY BUTTON

The safety is designed to stop the trigger mechanism.

The safety on any gun is a mechanical device, and it is not intended as a substitute for common sense or safe gun handling. Always keep the muzzle pointed in a safe direction.

- The safety is located behind the trigger, and provides protection against accidental or unintentional discharge under normal usage when properly engaged.
- To engage the safety, push the button from the left side so that it protrudes from the right side of the gun and the RED RING CAN NOT BE SEEN (Figure 2). The safe should always be in the “on” or “safe” position until you intend to fire the gun.
- When you are ready to fire the gun, press the safety button to the “off” or “fire” position, so that the safety protrudes from the left side of the shotgun and the RED RING APPEARS (Figure 3).

WARNING: The gun will fire when the trigger is pulled intentionally or accidentally when the RED RING APPEARS.



5-LOADING AND USAGE

WARNING: WHILE LOADING, KEEP THE SAFETY "ON" AT ALL TIMES AND KEEP THE MUZZLE AIMING AT A SAFE DIRECTION.

To load your pump action shotgun, check the carrier under the receiver. You will see that it is possible to move the carrier into the receiver. Now, insert shells into the magazine tube by pushing them using your thumb (Figure 4). To chamber a shell when you are done with loading, open (Figure 5) and close the action by pulling the forend backwards, and than moving it forward till the action is locked. As the first shell is chambered, you can now add one more shell into the magazine tube. Now, you are ready to fire. When the trigger is pulled, the shell in the chamber is fired. To extract the fired shell and chamber the next one, you need to open and close the action by pulling the forend backward, and moving it forward.

NOTE: Note that you do not need to push the action release lever after pulling the trigger, since the action unlocks automatically after the hammer falls and the action can be cycled without depressing the action release lever.



WARNING: To prevent unexpected ignition and potential injuries, be certain that each round you use is in the proper gauge!

Always keep your fingers away from the trigger while loading your gun!

6-UNLOADING

WARNING: WHILE UNLOADING, KEEP THE SAFETY "ON" AT ALL TIMES AND KEEP THE MUZZLE AIMING AT A SAFE DIRECTION.

To unload the shells in the chamber and magazine tube, push the action release lever located on the right side of the trigger guard protruding from the receiver (Figure 6). This releases the action, and you can now open&close the action. By pulling the forend backwards, and than moving it forward (opening&closing the action), the shell in the muzzle is extracted first, and than the ones in the magazine tube are extracted one by one (Figure 7).



7-DISASSEMBLY

To disassemble the shotgun, unscrew the forend retaining nut (Figure 8) remove the barrel by pulling it forward (Figure 9).

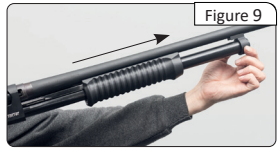

After that you can remove the forend/bolt assembly at once by moving them forward (Figure 10-11). Note that the forend, action bar and bolt are fixed together.

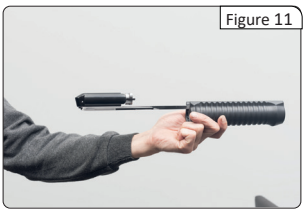

Using a tool like a pin (if necessary, with the support of a hammer) remove the trigger group housing pin (Figure 12) and take the trigger group housing out (Figure 13).

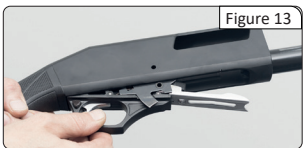

8-REASSEMBLY

- Follow the disassembly steps in reverse order starting with inserting the trigger group housing pin and finishing with screwing the forend retaining nut.
- Note that the hammer must be cocked to be able to reassemble the trigger group housing. Figure 14 shows the cocked state, and Figure 15 shows the decocked state of the hammer.

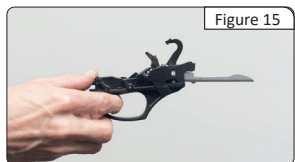

9- ADJUSTING LENGTH OF PULL (LOP SPACERS)

- You can extend the length of pull by placing LOP spacers between the buttpad and the stock. Your shotgun is provided with 3 pieces of 5 mm (0.2") LOP spacers.
- To adjust the length of pull of your shotgun, first remove the two screws located on the top and bottom of the buttpad using a screwdriver (Figure 16).
- The length of pull is the distance from the center of the trigger to the butt of the recoil pad.
- To achieve the desired length of pull, arrange the LOP spacers as shown in Figure 17.

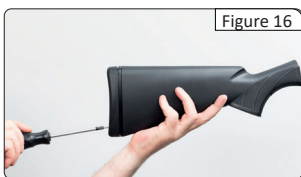

- After placing the LOP spacers, attach the recoil pad to the stock (Figure 18) and tighten the screws using a screwdriver in the opposite direction of how they were removed (Figure 19). To prevent wear on the buttpad and make the process smoother, it is recommended that the screwdriver tip be slightly greasy.



10-ADJUSTABLE STOCK

- Each shotgun is provided with a set of stock shims to assist the shooter in obtaining a personalized fit to the sighting plane. The stock is user adjustable for either cast or stock drop. This adjustment is made by replacing the plastic shim located between the receiver and the stock (Figure 20). Note that only one shim can be inserted between stock & receiver.



Figure 20



Figure 21

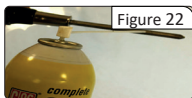

Figure 22

- The factory installed shim is marked CIP which provides a neutral cast and standard drop dimensions of the comb. The shim kit includes two replacement shims that change the cast of the stock, either Left 5 or Right 5. These spacers do not affect the stock drop.
- The kit includes three replacement shims that change the drop of the stock. The slope of the drop in the stock can be changed from standard to -10, or -5 or a positive 5 direction.
- Replacing the stock shim requires the removal of the butt pad. The butt pad is attached by two Philips head screws. To detach the pad;
- Locate the screws on the pad (Figure 21).
- Lubricate the shaft of the screw driver to prevent damaging the rubber pad (Figure 22).
- Once the pad is removed, loosen and remove the stock bolt and its washer using a wrench (Figure 23), and pull the stock free from the receiver (Figure 24). Note that it is not necessary to remove both of the screws on the pad; you may unscrew one of them and pivot the pad to gain access to the bolt.

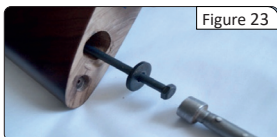

Figure 23



Figure 24

- Remove and replace the shim for a personalized stock fit (Figure 25), and re-attach the stock and tighten the stock bolt (Figure 26).
- Re-attach the butt pad with lubricated screw driver (Figure 27).



Figure 25



Figure 26

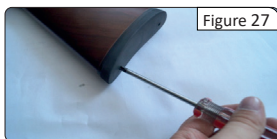







Figure 27

11-USE OF CHOKE TUBES

* Not all models are provided with mobile chokes.

With the choke tubes you can control the openness or tightness of the pattern of your shotgun. The chart below lists the chokes available (from open to tight), and the corresponding marks that indicate the choke of your shotgun.

AMERICAN DESIGNATION	CL (Cylinder)	IC (Improved Cylinder)	M (Modified)	IM (Improved Modified)	F (Full)
CHOKE TUBE					
NOTCHES	★★★★★	★★★★	★★★	★★	★
COMPATIBILITY WITH SLUGS	Recommended	Not Recommended	Not Recommended	Not Recommended	Not Recommended
COMPATIBILITY WITH STEEL SHOT	Recommended	Recommended	Recommended	Not Recommended	Not Recommended
BEST IN THE AREA OF	Sporting, clay and skeet shooting. Short distance, more open shooting.	Quail, dove and target shooting. For shorter distance more open shooting.	Hunting woodcock, pheasant & quail with 30-35 yard shots. Long range hunting with steel shot and tight groups.	For hunting pheasant, ducks with 30-40 yard shots.	For duck and goose hunting with 40-45 yard shots. For long range hunting with lead shot and tight groups.

* All choke tubes are included in the package in a specially designed box (Figure 28).



WARNING: When installing a choke tube in your barrel, make sure that the tube is completely screwed down tight in the barrel, never shoot your shotgun without the choke tubes installed as this may damage the barrel and injure the shooter. Choke tubes may become loose after extended firing and should be checked frequently for tightness.

11-USE OF CHOKE TUBES

INSTALLATION OF CHOKE TUBES

WARNING: Check that the firearm is unloaded. If not, unload the firearm by operating as described in the chapter “Unloading”. Never look into the muzzle or change tube on a loaded gun; even with safety is set to “ON”.

- Apply a thin coat of gun oil to the threads of the barrel and of the choke tube.
- Insert the desired chokes into the choke housing. Take care the notched end will be upside.
- Carefully hand screw the chokes into the barrels clockwise (Figure 29). Using the choke tube Wrench; tighten the choke until it is fully bottomed into its recess in the barrel.
- Remove the choke tube wrench after tightening.

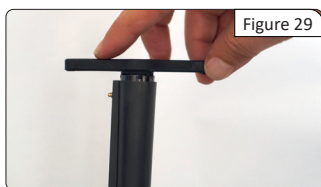

REMOVAL OF CHOKE TUBES

WARNING: Check that the firearm is unloaded. If not, unload the firearm by operating as described in the chapter “Unloading”. Never look into the muzzle or change tube on a loaded gun, even with safety engaged.

- Unscrew (counterclockwise) the choke tube using the choke tube wrench supplied (Figure 30). Remove the choke tube from the muzzle (Figure 31).

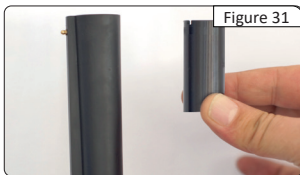
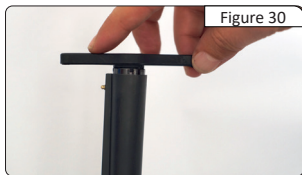

CLEANING OF CHOKE TUBES

WARNING: Check that the firearm is unloaded. If not, unload the firearm by operating as described in the chapter “Unloading”. Never look into the muzzle or change tube on a loaded gun, even with safety is set to “ON”.

- Carefully clean the choke housing. If necessary, use a cotton patch coated with gun oil.
- Check the choke to make sure it is perfectly clean inside and outside.
- Apply a thin coat of gun oil to the threads of the barrel and of the choke tube.

12-PARTS LIST

1	Receiver
2	Magazine Tube
3	Magazine Spring
4	Rear Magazine Plug
5	Front Magazine Plug
7	Through Bolt
8	Stock Washer
9	Stock Retaining Nut
9-C	Buttplate Retaining Screw
9-F	Adj. Comb Spacers (3x)
9-G	Comb Retaining Screws (2x)
10	Trigger Group Retaining Pin
11	Picatinny Rail
11-A	Picatinny Rail Retaining Screw(2 Pcs.)
12	Carrier Lock Pin
13	Carrier Lock
13-A	LOP Spacer
14	Carrier Lock Spring
15	Shell Latch
16	Shell Latch Spring
17	Shell Latch Pin
18	Ratchet Screw
19	Ratchet Spring
20	Ratchet Pin
21	Forend Retaining Nut
22	Stock
22-T	Tactical Stock
23	Forend
24	Forend Retaining Ring
25-A	Barrel (Tactical)
25-B	Barrel (Top Rib)
25-K	Barrel Extension
26	Mobile Choke
27	Extractor Spring
28	Extractor

29	Extractor Retaining Pin
30	Locking Block
32	Firing Pin Spring
33	Firing Pin
34	Firing Pin Screw
37	Forend/Bolt Assembly
40	Safety
41	Safety Spring Guide
42	Safety Spring
43	Safety Spring Pin
44	Trigger
45	Disconnecter Spring
46	Disconnecter Spring Pin
47	Disconnecter
48	Disconnecter Pin
49	Trigger Spring
50	Trigger Stop Pin
51	Trigger Pin
52	Action Release Lever Spring
53	Action Release Lever
54	Hammer Stop Retainer Pin
55	Hammer Retainer Bushing
56	Hammer Stop
57	Retaining Circlip
58	Trigger Group Housing
59	Hammer Spring
60	Hammer Spring Guide
61	Hammer
62	Carrier Lever Pin Bearing
63	Carrier Lever
64	Carrier Lever Spring Pin
65	Carrier Lever Spring
66	Carrier
67	Carrier Lever Rivet

13-EXPLODED VIEW

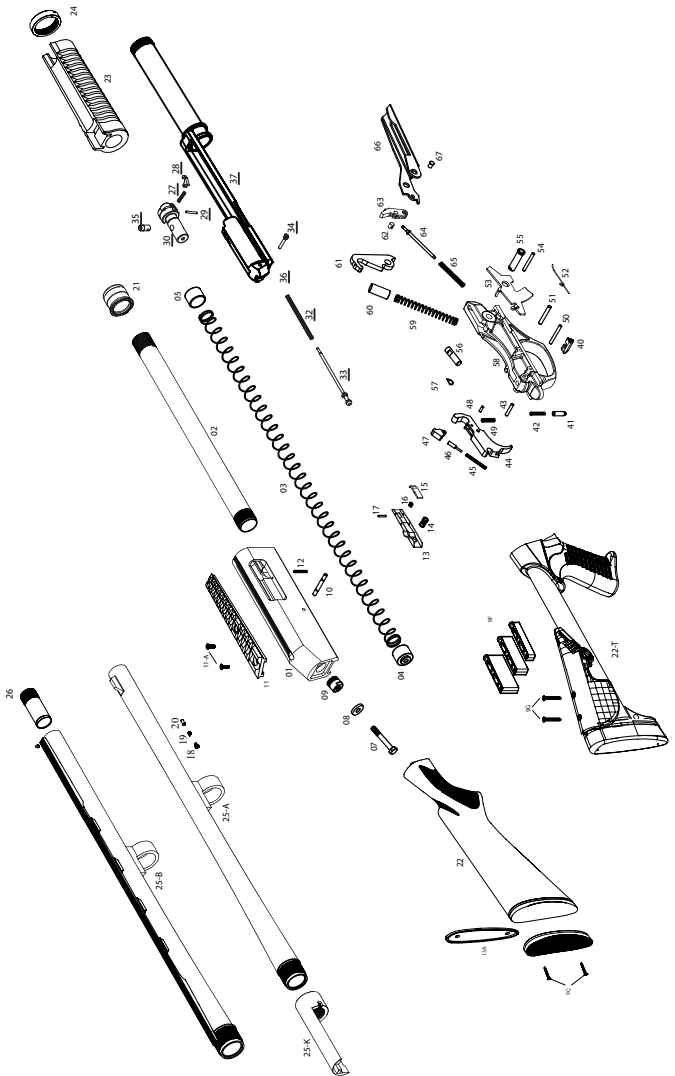

14-CLEANING AND MAINTENANCE

WARNING: ENSURE THAT YOUR FIREARM IS UNLOADED BEFORE BEGINNING TO CLEAN IT.

At the end of the day of shooting/hunting, clean and lubricate the shotgun.

Cleaning procedure:

- Disassemble the shotgun (see paragraph “Disassembly”).
- Clean the bores with care by passing a cleaning rod with a cotton patch coated with a high-quality gun oil to remove combustion residues. Also include the chambers in your cleaning operation.
- Do not forget to clean choke tubes (if available) and choke seats in the muzzle. Failure to clean these areas will result in the inability to remove the choke from the barrel and severe damage to the muzzle. If a choke tube becomes tight in the muzzle, this is an indication that the thread requires cleaning.
- Run a clean dry patch through the bores to remove oil residues.
- Lightly oil the inside of the barrels with a clean cotton patch coated in high-quality gun oil.
- Clean with care the external surfaces of the shotgun to remove any trace of dirt, sweat and fingerprints.
- Make sure you do not touch the metal parts while you are putting your shotgun back into its place of storage.

Always follow the instructions provided with your gun cleaner and gun lubricant.

Whenever your firearm has been exposed to sand, dust, extreme humidity water or other adverse conditions, it must be cleaned and lubricated.

After an intensive period of use, check the operation of the bolt assembly and if necessary, clean and lubricate it using suitable gun oil.

If your firearm seats used in a cold climate, be sure to use an oil of an appropriate weight so that it will not congeal in cold temperatures.

NEVER MANIPULATE, ADJUST OR CHANGE ANY OF THE INTERNAL COMPONENTS OF YOUR FIREARM.

ANY MAINTENANCE, ADJUSTMENT OR SERVICE NOT SPECIFIED IN THIS MANUAL MAY AFFECT THE SAFETY AND RELIABILITY OF YOUR FIREARM AND MUST BE PERFORMED BY AN AUTHORIZED GUN-SMITH USING GENUINE FACTORY PARTS. IF YOU DO OTHERWISE, IMPROPER FUNCTIONING OF YOUR FIREARM MAY OCCUR AND SERIOUS INJURY OR DEATH MAY RESULT.

When storing, do not encase the shotgun in anything that will attract or hold moisture, for example; leather or heavy cloth. Also, do not store shotguns with a plug inserted in the barrel for this can be a contributing factor to moisture accumulation. If the shotgun is to be stored for an extended period, the bore, chamber and internal surfaces should be oiled with a high-quality lubricating oil preservative intended for firearms.

The external parts; receiver, bolt and barrel should be coated with an anti-rust oil.

Windham Weaponry



Rev : WW01-050925